

Exercise 4.1 : Solutions of Questions on Page Number : 60

Q1 :

Construct the following quadrilaterals.

(i) Quadrilateral ABCD

$$AB = 4.5 \text{ cm}$$

$$BC = 5.5 \text{ cm}$$

$$CD = 4 \text{ cm}$$

$$AD = 6 \text{ cm}$$

$$AC = 7 \text{ cm}$$

(ii) Quadrilateral JUMP

$$JU = 3.5 \text{ cm}$$

$$UM = 4 \text{ cm}$$

$$MP = 5 \text{ cm}$$

$$PJ = 4.5 \text{ cm}$$

$$PU = 6.5 \text{ cm}$$

(iii) Parallelogram MORE

$$OR = 6 \text{ cm}$$

$$RE = 4.5 \text{ cm}$$

$$EO = 7.5 \text{ cm}$$

(iv) Rhombus BEST

$$BE = 4.5 \text{ cm}$$

$$ET = 6 \text{ cm}$$

Answer :

(i) Firstly, a rough sketch of this quadrilateral can be drawn as follows.

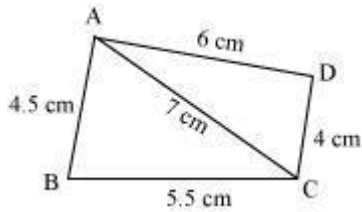

(1) $\triangle ABC$ can be constructed by using the given measurements as follows.

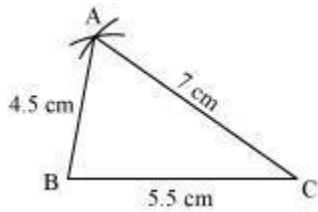

(2) Vertex D is 6 cm away from vertex A. Therefore, while taking A as centre, draw an arc of radius 6 cm.

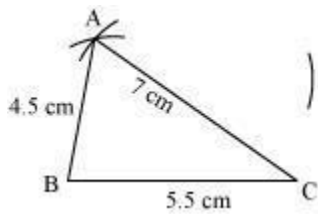

(3) Taking C as centre, draw an arc of radius 4 cm, cutting the previous arc at point D. Join D to A and C.

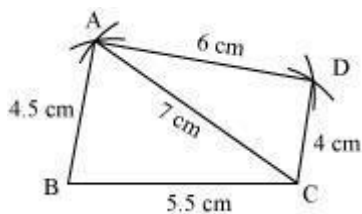

ABCD is the required quadrilateral.

(ii) Firstly, a rough sketch of this quadrilateral can be drawn as follows.

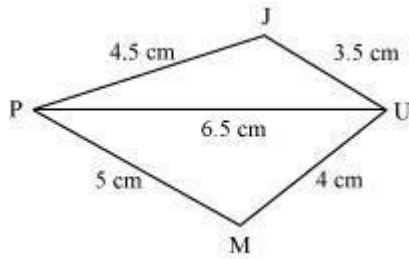

(1) ΔJUP can be constructed by using the given measurements as follows.

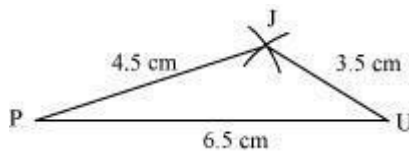

(2) Vertex M is 5 cm away from vertex P and 4 cm away from vertex U. Taking P and U as centres, draw arcs of radii 5 cm and 4 cm respectively. Let the point of intersection be M.

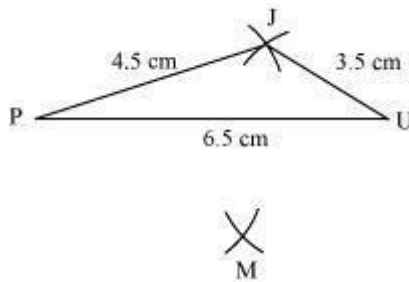

(3) Join M to P and U.

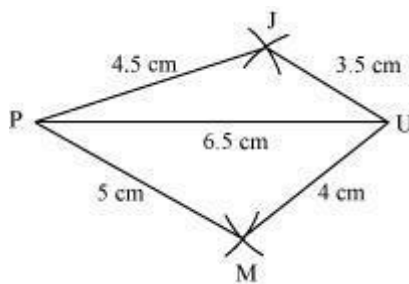

JUMP is the required quadrilateral.

(iii) We know that opposite sides of a parallelogram are equal in length and also these are parallel to each other.

Hence, $ME = OR$, $MO = ER$

A rough sketch of this parallelogram can be drawn as follows.

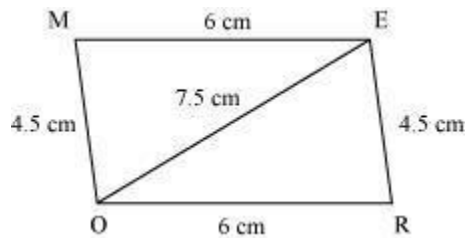

(1) $\triangle EOR$ can be constructed by using the given measurements as follows.

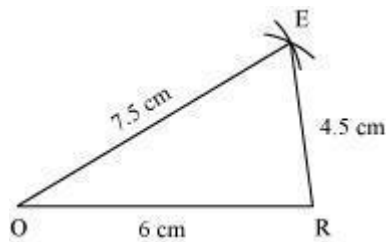

(2) Vertex M is 4.5 cm away from vertex O and 6 cm away from vertex E. Therefore, while taking O and E as centres, draw arcs of 4.5 cm radius and 6 cm radius respectively. These will intersect each other at point M.

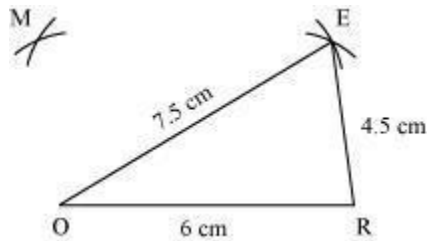

(3) Join M to O and E.

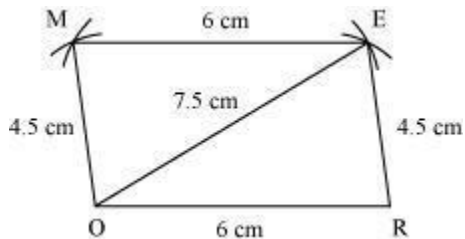

MORE is the required parallelogram.

(iv) We know that all sides of a rhombus are of the same measure.

Hence, $BE = ES = ST = TB$

A rough sketch of this rhombus can be drawn as follows.

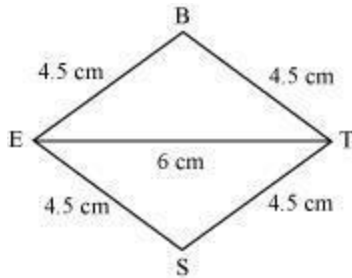

(1) $\triangle BET$ can be constructed by using the given measurements as follows.

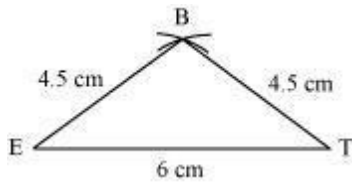

(2) Vertex S is 4.5 cm away from vertex E and also from vertex T. Therefore, while taking E and T as centres, draw arcs of 4.5 cm radius, which will be intersecting each other at point S.

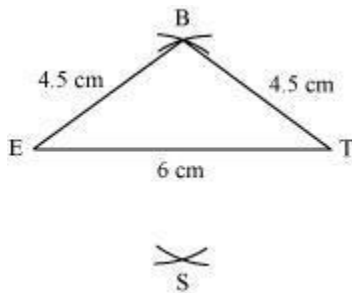

Exercise 4.2 : Solutions of Questions on Page Number : 62

Q1 :

Construct the following quadrilaterals.

(i) Quadrilateral LIFT

LI = 4 cm

IF = 3 cm

TL = 2.5 cm

$$LF = 4.5 \text{ cm}$$

$$IT = 4 \text{ cm}$$

(ii) Quadrilateral GOLD

$$OL = 7.5 \text{ cm}$$

$$GL = 6 \text{ cm}$$

$$GD = 6 \text{ cm}$$

$$LD = 5 \text{ cm}$$

$$OD = 10 \text{ cm}$$

(iii) Rhombus BEND

$$BN = 5.6 \text{ cm}$$

$$DE = 6.5 \text{ cm}$$

Answer :

(i) A rough sketch of this quadrilateral can be drawn as follows.

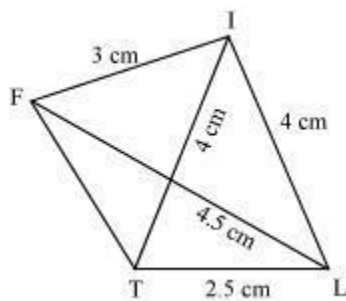

(1) ΔITL can be constructed by using the given measurements as follows.

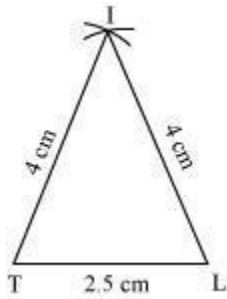

- (2) Vertex F is 4.5 cm away from vertex L and 3 cm away from vertex I. Therefore, while taking L and I as centres, draw arcs of 4.5 cm radius and 3 cm radius respectively, which will be intersecting each other at point F.

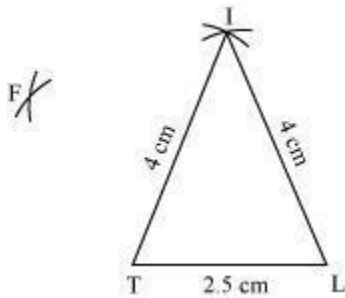

- (3) Join F to T and F to I.

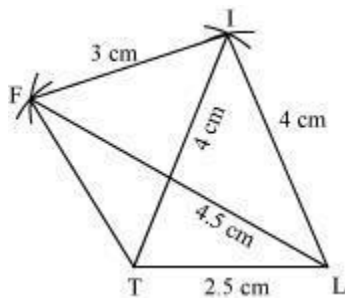

LIFT is the required quadrilateral.

- (ii) A rough sketch of this quadrilateral can be drawn as follows.

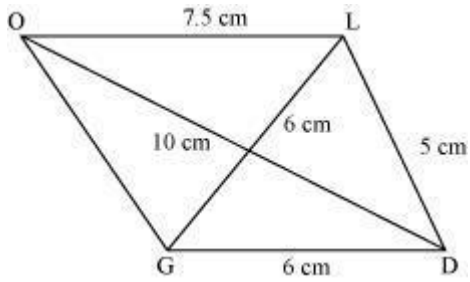

(1) $\triangle GDL$ can be constructed by using the given measurements as follows.

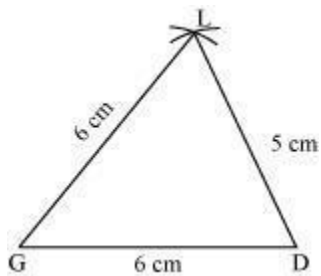

(2) Vertex O is 10 cm away from vertex D and 7.5 cm away from vertex L. Therefore, while taking D and L as centres, draw arcs of 10 cm radius and 7.5 cm radius respectively. These will intersect each other at point O.

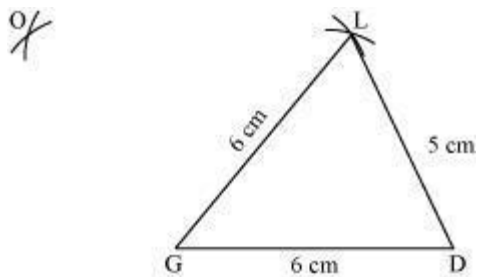

(3) Join O to G and L.

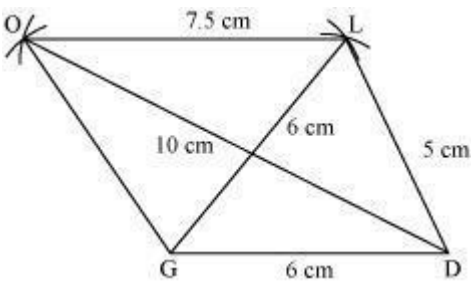

GOLD is the required quadrilateral.

(iii) We know that the diagonals of a rhombus always bisect each other at 90° . Let us assume that these are intersecting each other at point O in this rhombus.

Hence, $EO = OD = 3.25$ cm

A rough sketch of this rhombus can be drawn as follows.

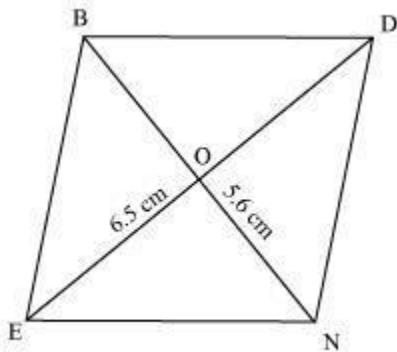

(1) Draw a line segment BN of 5.6 cm and also draw its perpendicular bisector. Let it intersect the line segment BN at point O.

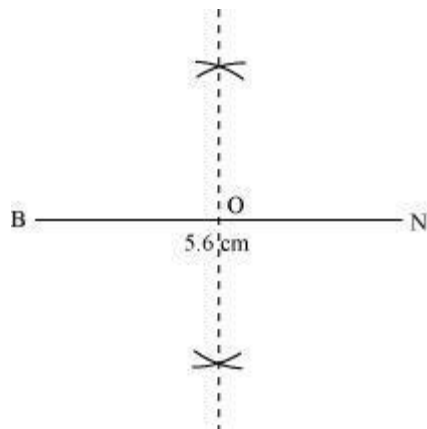

(2) Taking O as centre, draw arcs of 3.25 cm radius to intersect the perpendicular bisector at point D and E.

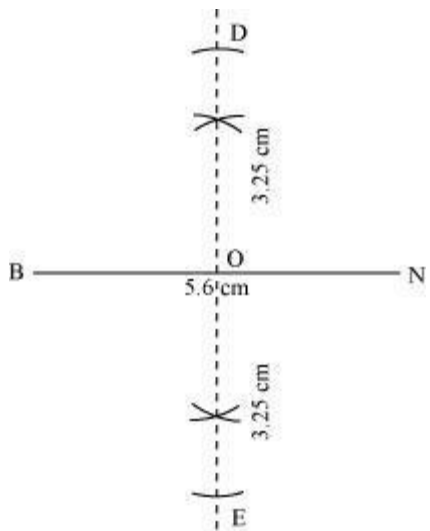

(3) Join points D and E to points B and N.

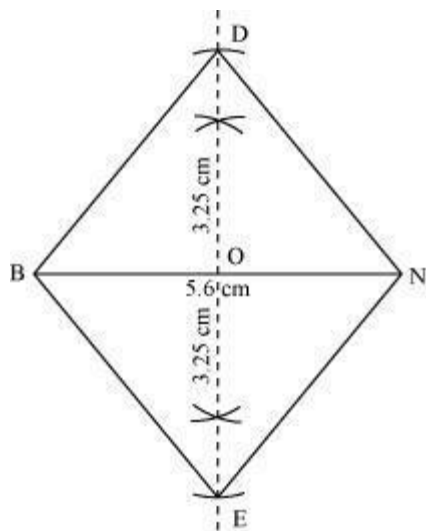

BEND is the required quadrilateral.

Exercise 4.3 : Solutions of Questions on Page Number : 64

Q1 :

Construct the following quadrilaterals.

(i) Quadrilateral MORE

MO = 6 cm

OR = 4.5 cm

$$\angle M = 60^\circ$$

$$\angle O = 105^\circ$$

$$\angle R = 105^\circ$$

(ii) Quadrilateral PLAN

$$PL = 4 \text{ cm}$$

$$LA = 6.5 \text{ cm}$$

$$\angle P = 90^\circ$$

$$\angle A = 110^\circ$$

$$\angle N = 85^\circ$$

(iii) Parallelogram HEAR

$$HE = 5 \text{ cm}$$

$$EA = 6 \text{ cm}$$

$$\angle R = 85^\circ$$

(iv) Rectangle OKAY

$$OK = 7 \text{ cm}$$

$$KA = 5 \text{ cm}$$

Answer :

(i)

(1) A rough sketch of this quadrilateral can be drawn as follows.

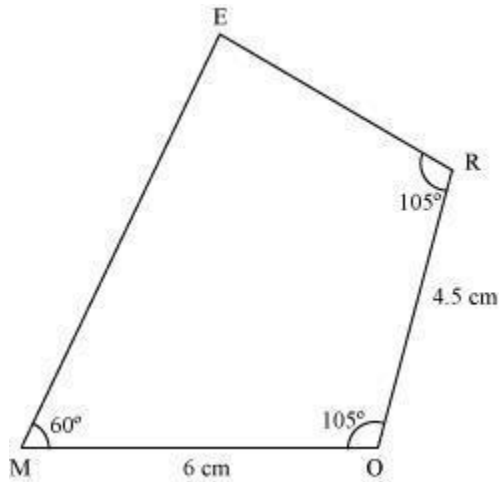

(2) Draw a line segment MO of 6 cm and an angle of 105° at point O. As vertex R is 4.5 cm away from the vertex O, cut a line segment OR of 4.5 cm from this ray.

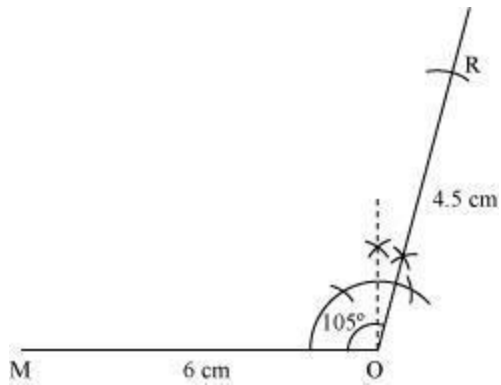

(3) Again, draw an angle of 105° at point R.

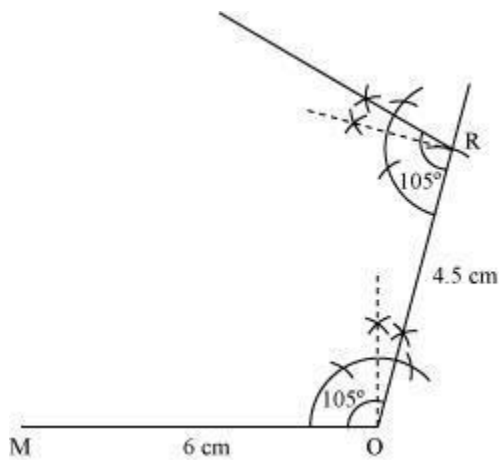

(4) Draw an angle of 60° at point M. Let this ray meet the previously drawn ray from R at point E.

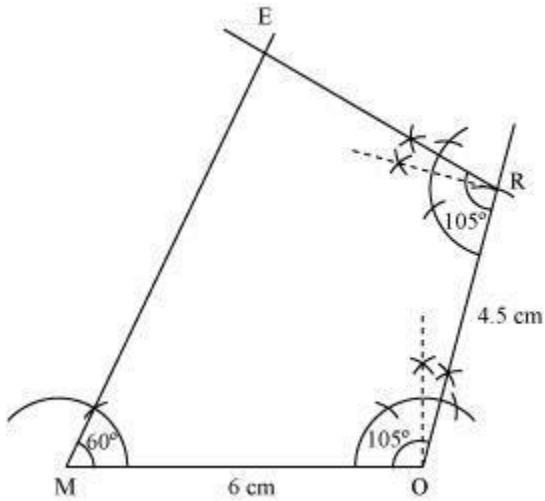

MORE is the required quadrilateral.

(ii)

(1) The sum of the angles of a quadrilateral is 360° .

In quadrilateral PLAN, $\angle P + \angle L + \angle A + \angle N = 360^\circ$

$$90^\circ + \angle L + 110^\circ + 85^\circ = 360^\circ$$

$$285^\circ + \angle L = 360^\circ$$

$$\angle L = 360^\circ - 285^\circ = 75^\circ$$

(2) A rough sketch of this quadrilateral is as follows.

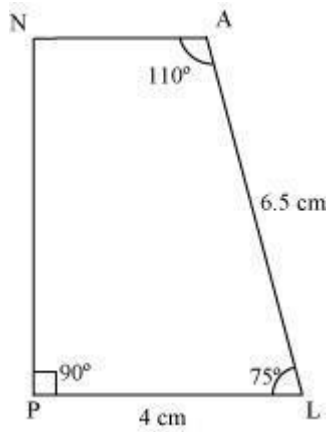

- (3) Draw a line segment PL of 4 cm and draw an angle of 75° at point L. As vertex A is 6.5 cm away from vertex L, cut a line segment LA of 6.5 cm from this ray.

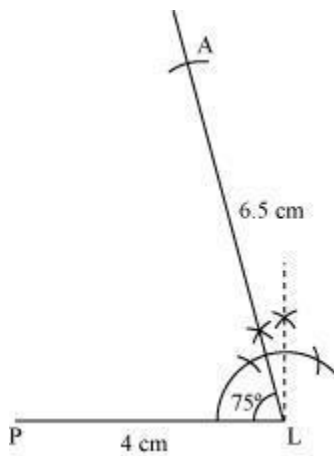

- (4) Again draw an angle of 110° at point A.

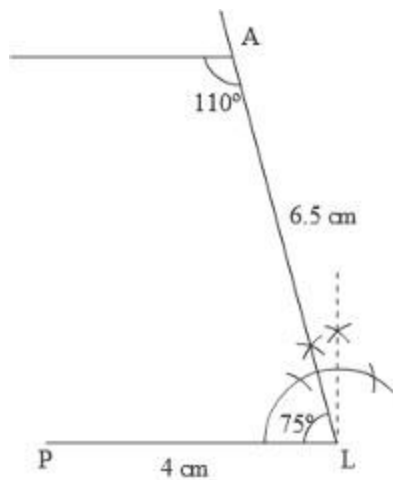

(5) Draw an angle of 90° at point P. This ray will meet the previously drawn ray from A at point N.

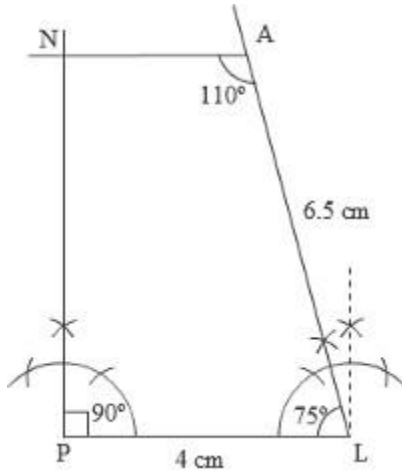

PLAN is the required quadrilateral.

(iii)

(1) Firstly, a rough sketch of this quadrilateral is as follows.

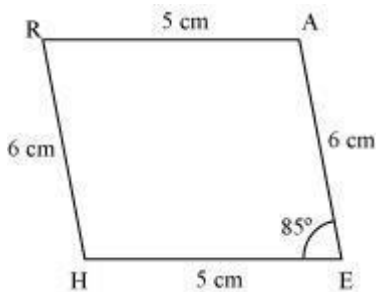

(2) Draw a line segment HE of 5 cm and an angle of 85° at point E. As vertex A is 6 cm away from vertex E, cut a line segment EA of 6 cm from this ray.

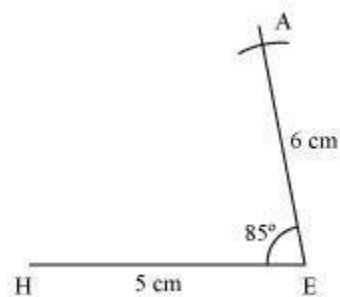

(3) Vertex R is 6 cm and 5 cm away from vertex H and A respectively. By taking radius as 6 cm and 5 cm, draw arcs from point H and A respectively. These will be intersecting each other at point R.

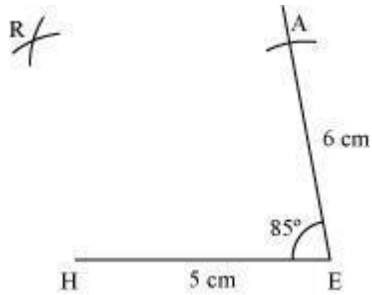

4. Join R to H and A.

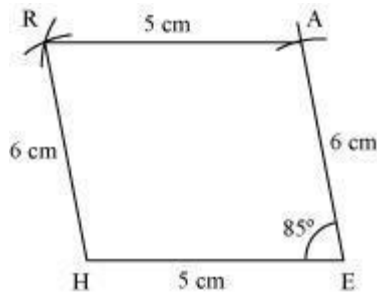

HEAR is the required quadrilateral.

(iv)

(1) A rough sketch of this quadrilateral is drawn as follows.

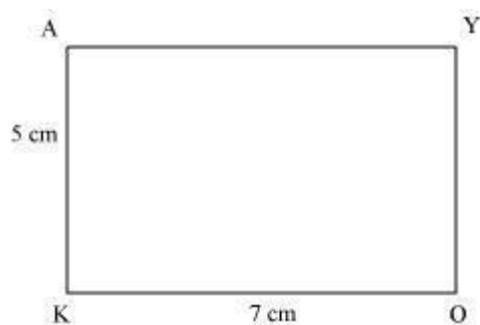

(2) Draw a line segment OK of 7 cm and an angle of 90° at point K. As vertex A is 5 cm away from vertex K, cut a line segment KA of 5 cm from this ray.

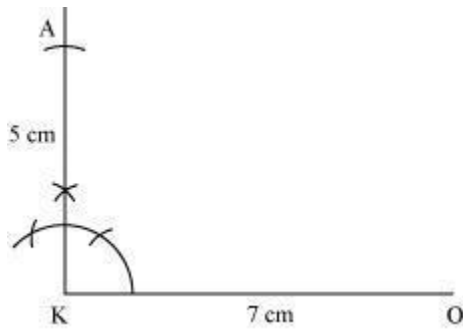

(3) Vertex Y is 5 cm and 7 cm away from vertex O a

Exercise 4.4 : Solutions of Questions on Page Number : 67

Q1 :

Construct the following quadrilaterals,

(i) Quadrilateral DEAR

DE = 4 cm

EA = 5 cm

AR = 4.5 cm

$\angle E = 60^\circ$

$\angle A = 90^\circ$

(ii) Quadrilateral TRUE

TR = 3.5 cm

RU = 3 cm

UE = 4 cm

$\angle R = 75^\circ$

$\angle U = 120^\circ$

Answer :

(i)

(1) A rough sketch of this quadrilateral can be drawn as follows.

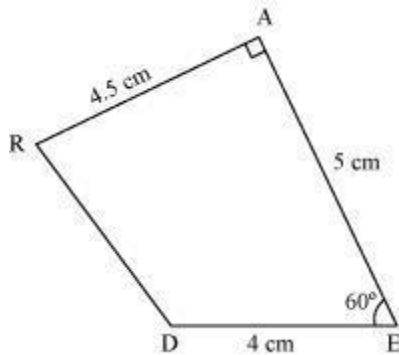

(2) Draw a line segment DE of 4 cm and an angle of 60° at point E. As vertex A is 5 cm away from vertex E, cut a line segment EA of 5 cm from this ray.

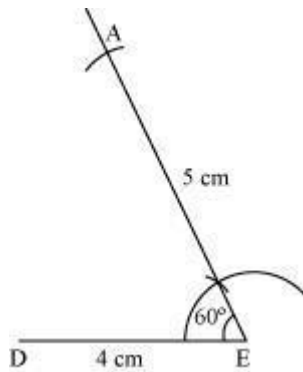

(3) Again draw an angle of 90° at point A. As vertex R is 4.5 cm away from vertex A, cut a line segment RA of 4.5 cm from this ray.

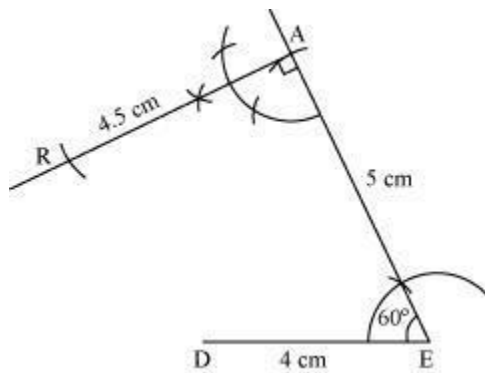

(4) Join D to R.

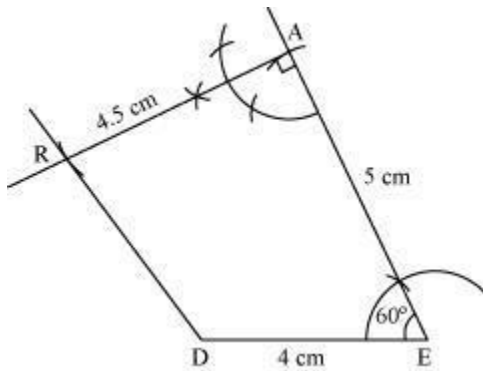

DEAR is the required quadrilateral.

(ii)

(1) A rough sketch of this quadrilateral can be drawn as follows.

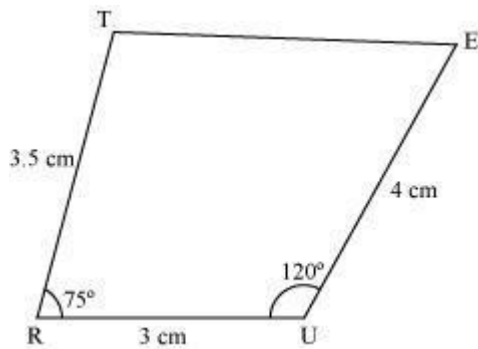

(2) Draw a line segment RU of 3 cm and an angle of 120° at point U. As vertex E is 4 cm away from vertex U, cut a line segment UE of 4 cm from this ray.

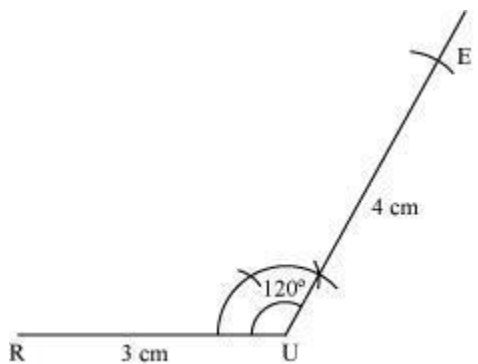

(3) Next, draw an angle of 75° at point R. As vertex T is 3.5 cm away from vertex R, cut a line segment RT of 3.5 cm from this ray.

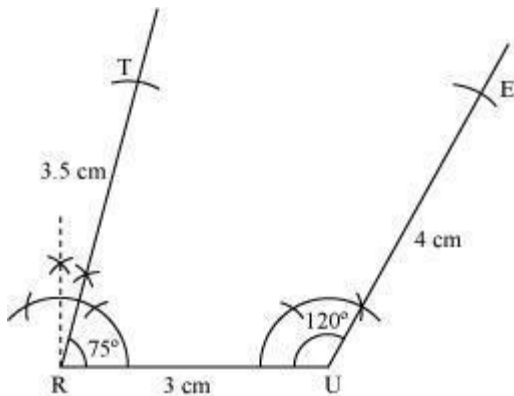

(4) Join T to E.

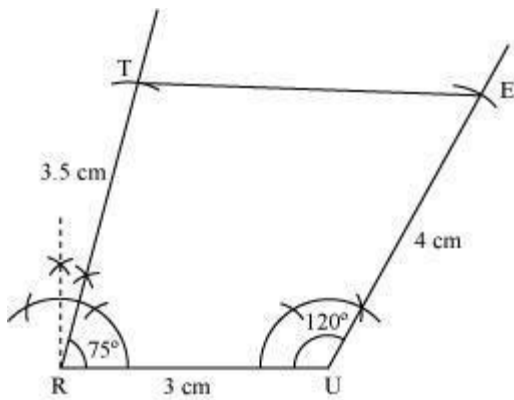

TRUE is the required quadrilateral.

Exercise 4.5 : Solutions of Questions on Page Number : 68

Q1 :

Draw the following:

The square READ with $RE = 5.1$ cm

Answer :

All the sides of a square are of the same measure and also all the interior angles of a square are of 90° measure. Therefore, the given square READ can be drawn as follows.

(1) A rough sketch of this square READ can be drawn as follows.

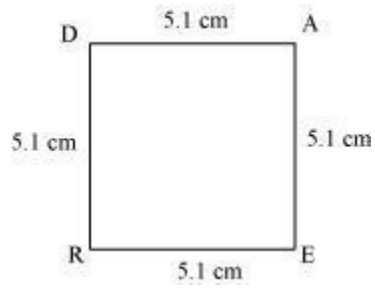

(2) Draw a line segment RE of 5.1 cm and an angle of 90° at point R and E.

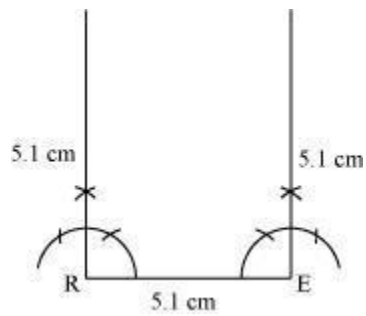

(3) As vertex A and D are 5.1 cm away from vertex E and R respectively, cut line segments EA and RD, each of 5.1 cm from these rays.

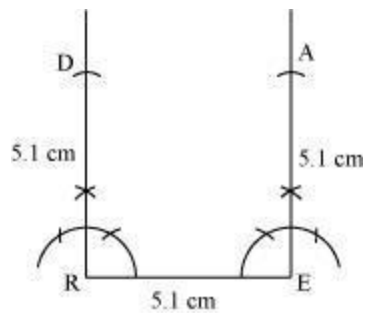

(4) Join D to A.

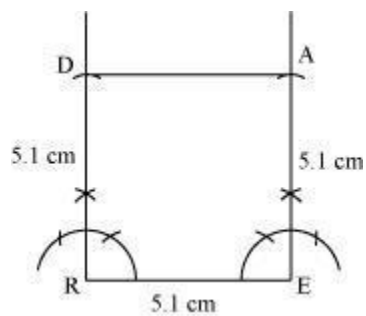

READ is the required square.

Q2 :

Draw the following:

A rhombus whose diagonals are 5.2 cm and 6.4 cm long.

Answer :

In a rhombus, diagonals bisect each other at 90° . Therefore, the given rhombus ABCD can be drawn as follows.

(1) A rough sketch of this rhombus ABCD is as follows.

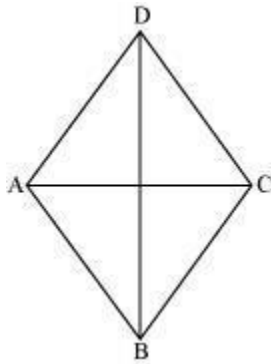

(2) Draw a line segment AC of 5.2 cm and draw its perpendicular bisector. Let it intersect the line segment AC at point O.

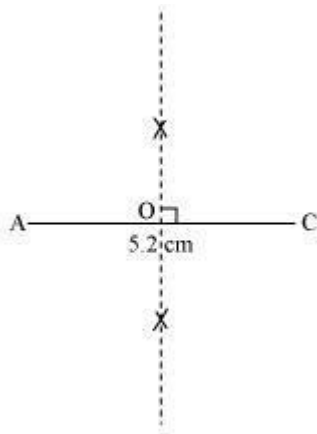

(3) Draw arcs of $\frac{6.4 \text{ cm}}{2} = 3.2 \text{ cm}$ on both sides of this perpendicular bisector. Let the arcs intersect the perpendicular bisector at point B and D.

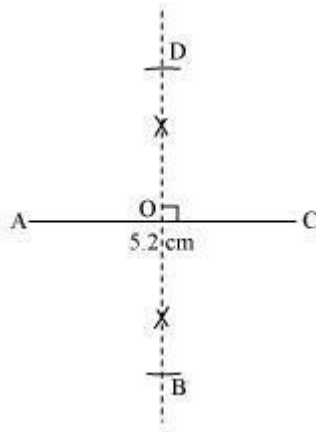

(4) Join points B and D with points A and C.

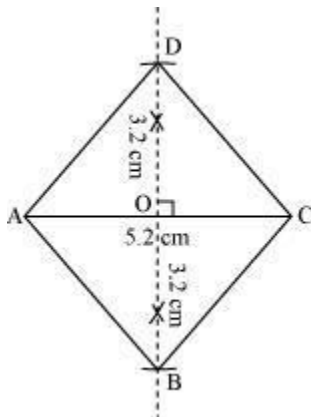

ABCD is the required rhombus.

Q3 :

Draw the following:

A rectangle with adjacent sides of length 5 cm and 4 cm.

Answer :

Opposite sides of a rectangle have their lengths of same measure and also, all the interior angles of a rectangle are of 90° measure. The given rectangle ABCD may be drawn as follows.

(1) A rough sketch of this rectangle ABCD can be drawn as follows.

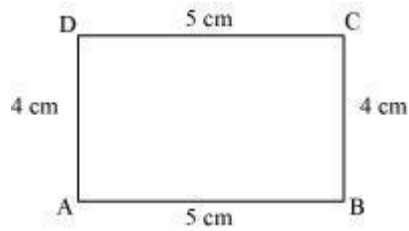

(2) Draw a line segment AB of 5 cm and an angle of 90° at point A and B.

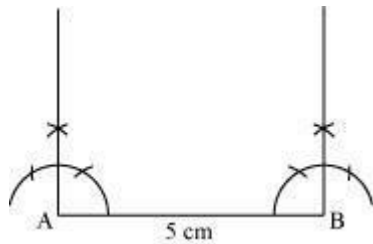

(3) As vertex C and D are 4 cm away from vertex B and A respectively, cut line segments AD and BC, each of 4 cm, from these rays.

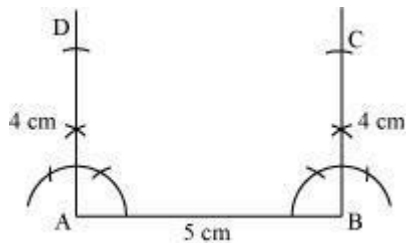

(4) Join D to C.

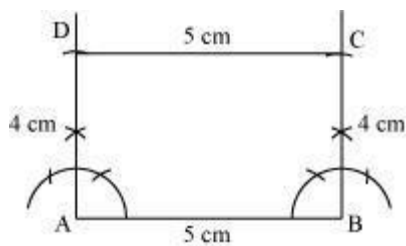

ABCD is the required rectangle.

Q4 :

Draw the following:

A parallelogram OKAY where $OK = 5.5$ cm and $KA = 4.2$ cm.

Answer :

Opposite sides of a parallelogram are equal and parallel to each other. The given parallelogram OKAY can be drawn as follows.

(1) A rough sketch of this parallelogram OKAY is drawn as follows.

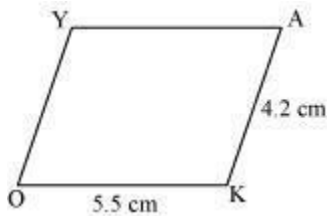

(2) Draw a line segment OK of 5.5 cm and a ray at point K at a convenient angle.

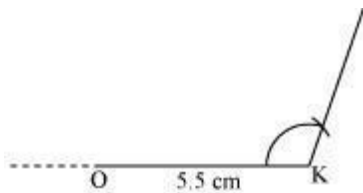

(3) Draw a ray at point O parallel to the ray at K. As the vertices, A and Y, are 4.2 cm away from the vertices K and O respectively, cut line segments KA and OY, each of 4.2 cm, from these rays.

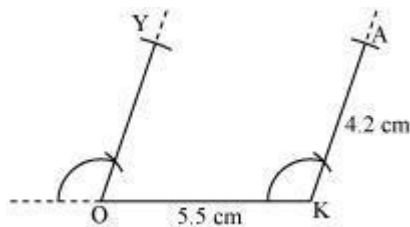

(4) Join Y to A.

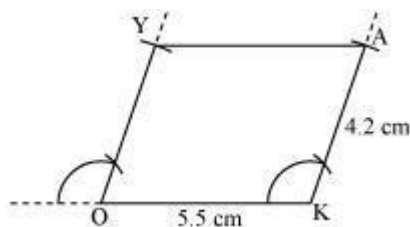



OKAY is the required parallelogram.